

LIFT-SLIDE



The all new A3 Explorer inside glazed Lift-Slide door. Tested to 3m high and 2m wide panels. Hardware carrying capacity 400kg per panel.

HBS
ALUMINIUM SYSTEMS



Lift-Slide

- for the Architect

BENEFITS OF HBS LIFT-SLIDE

- Designed for large, heavy doors.
- High security, up to 5 lock points.
- Excellent weather performance.
- Long service life.
- Extensive, accredited testing.

RECOMMENDED SIZES

- 3000mm max. panel height
- 2000mm max panel width.
- 400kg max. panel weight.

(on request wider, taller, heavier panels possible)

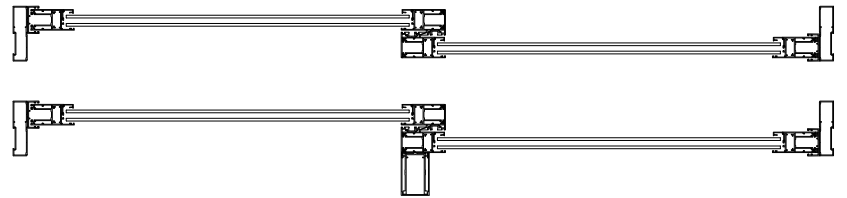
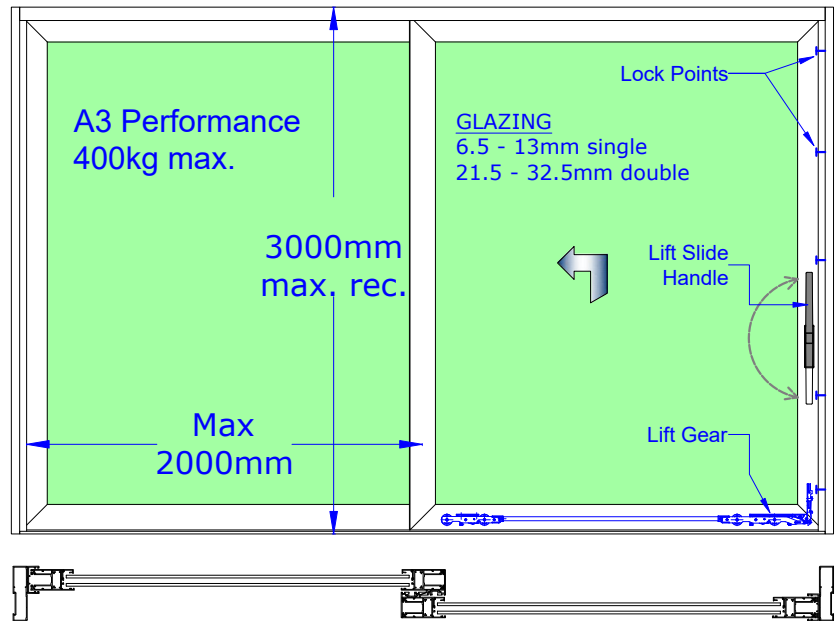

PRODUCT TYPES

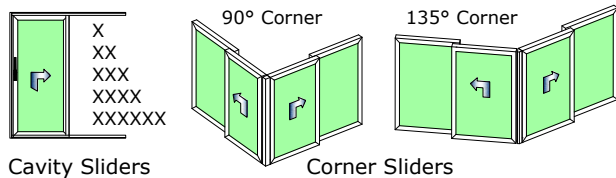
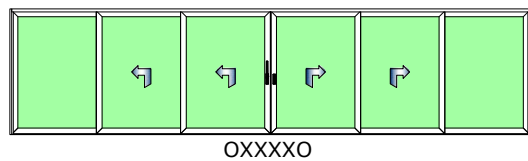
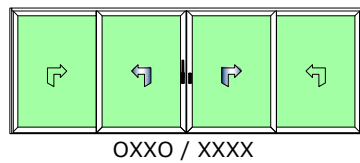
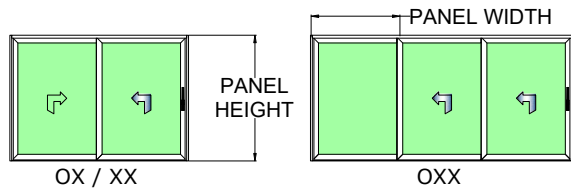

ADD-ON STIFFENERS

① Interlock- standard

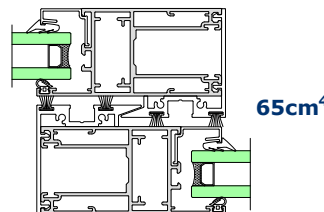

② Interlock w. 90mm stiffener

③,④ w. Steel box.

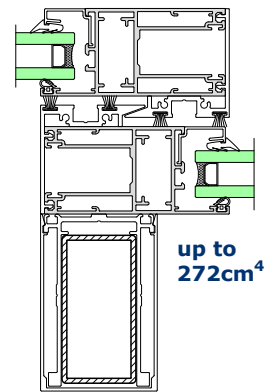

- 90mm add-on stiffener provides for larger panels.
- Optional steel box insert.

LIFT-GEAR BY ROTO

- Designed in stainless steel and aluminium alloy.
- Used extensively overseas.
- Durable frictionless movement.
- 400kg rollers available.

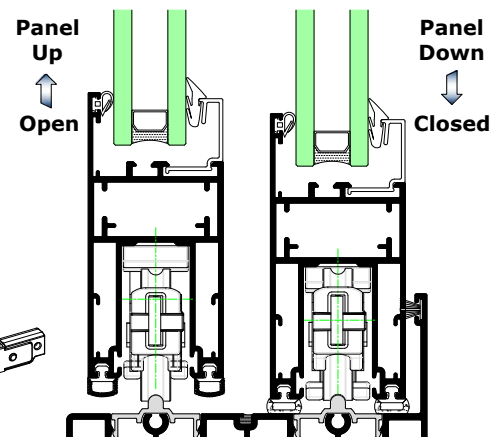
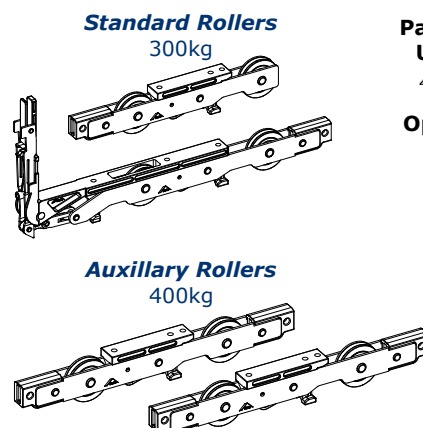



Lift-Slide

- for the Fabricator

**Accredited Laboratory
Test Certificate**
SANS 613:2011

THIS CERTIFICATE RECORDS THE SUCCESSFUL TESTING OF THE TEST SAMPLE INDICATED BELOW IN ACCORDANCE WITH SOUTH AFRICAN FENESTRATION PRODUCT STANDARD SANS613:2011 *incl. par. 5.7*

A3 PERFORMANCE CLASS	MANUFACTURER: HBS ALUMINIUM SYSTEMS	WATER PRESSURE: 400 [PA]	DATE OF ISSUE: 11 NOV 2021
	TEST SAMPLE: HBS Lift & Slide	DEFLECTION PRESSURE: 2000 [PA]	
	SYSTEM SUPPLY: HBS ALUMINIUM SYSTEMS	STRUCTURAL PRESSURE: 3000 [PA]	
	TEST NUMBER: HBS21/13	AIR INFILTRATION: 0.811 [L/sec/m²]	

TEST SAMPLE DETAILS:

DESCRIPTION: HBS EXPLORER LIFT-SLIDE
 OXX TYPE DOOR
 DRAWING NAME: HBS21-13 LS OXX.PDF
 NO. OF PAGES: 15

PROFILES USED ON TEST SAMPLE (CODE & DESCRIPTION):

PANEL PROFILE:	AB6031, 45mm
INTERLOCK:	AB6034 56mm
FRAME SILL:	AB191 180mm
FRAME TOP:	AB195 180mm
FRAME JAMB:	AB189 180mm
TRACK:	AB6037, 5mm
STIFFENER:	AB6038, 90mm
STIFFENER COVER:	AB6036, 90mm
DOOR STEP:	AB185
DRAIN:	AB189, 180mm

PERFORMANCE, SANS613

- SANS613 A3 (2000pa) performance rating.
- Ideal for domestic, commercial and hi-rise use.
- Inland or coastal application.
- A3 can be achieved across the range of OX, OXX, OX|XO, OXX|XXO.
- A1 can be expected for XX,XXX,XX|XX and other multi-slider types.

PERFORMANCE CHART

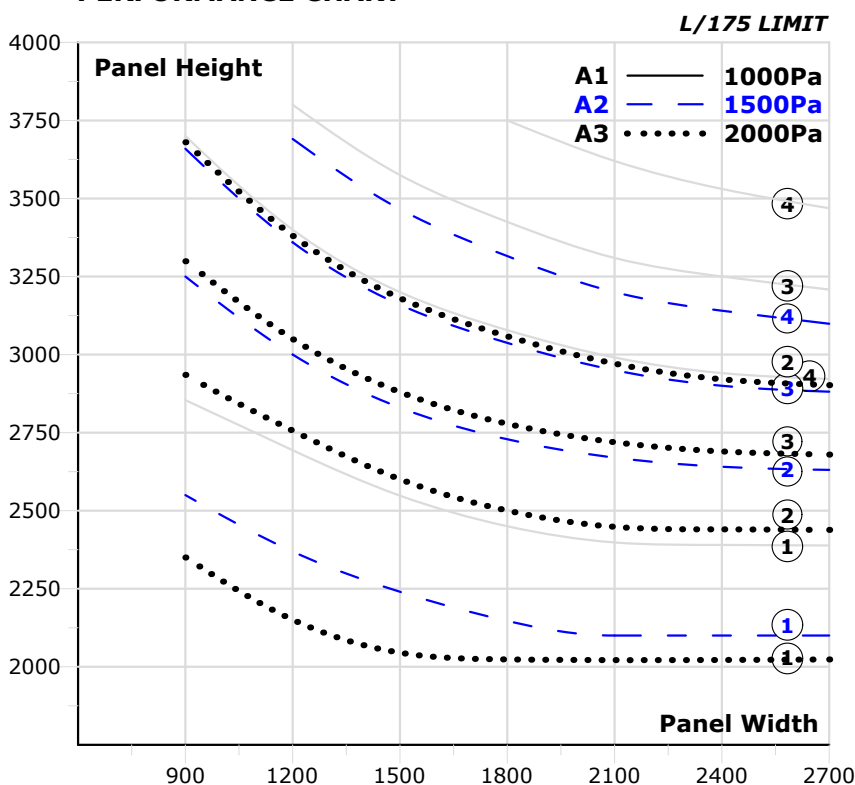

HANDLES

- HBS Flush handles in black.
 - ROTO handles single & double sided, locking & non-locking.
- Stocked in black (gold & silver on req.)

FLUSH LIFT HANDLE

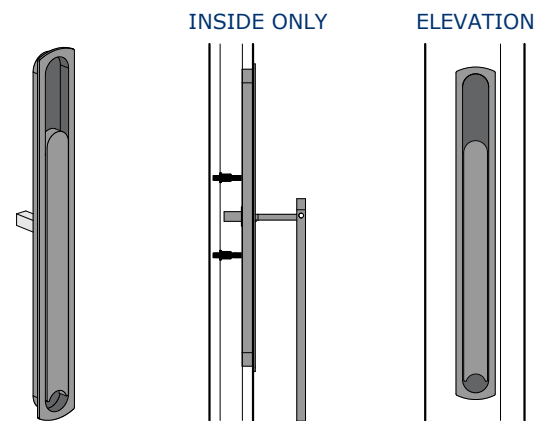

ROTO LIFT HANDLE

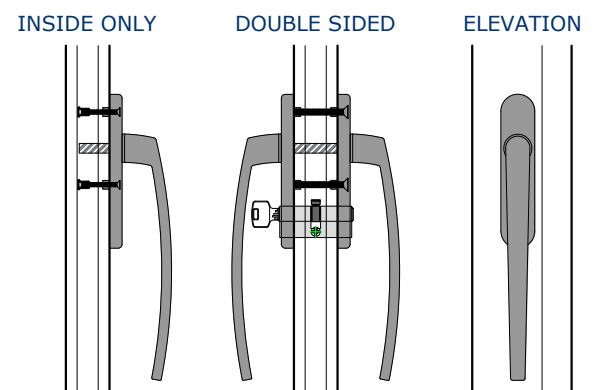

PRECISION FABRICATION

- Quick, accurate punching.
- Increases productivity
- Reduces wastage.

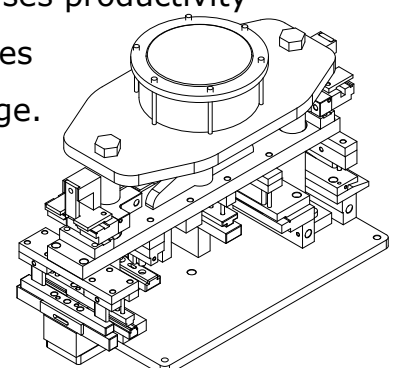

REASONS WHY ARCHITECTS, FABRICATORS AND HOME OWNERS LOVE OUR LIFT-SLIDE DOOR

1. TESTED TO THE LIMIT

It is the only Lift-Slide door system available in South Africa and tested under SANAS accreditation to SANS613:2011. Every system from HBS is tested to its limits for your peace of mind.

2. COST EFFECTIVE

It is by far the most cost-effective Lift-Slide door available in South Africa, which means that a Lift-Slide door is more affordable than ever before.

3. LOCALLY STOCKED & SUPPORTED

Lift-Slide profiles and hardware are available off the shelf, so no extended lead times. Place the order, choose the colour and you will be fabricating and installing in no time.

4. CLASSIC GERMAN HARDWARE

German engineered hardware with superior corrosion performance ensures long service life.

5. SIMPLER

Designed with less components than any imported European system which makes our Lift-Slide door ideal for South African conditions.

A Lift-Slide door that Architects and Fabricators can trust.

